

# Legend 2

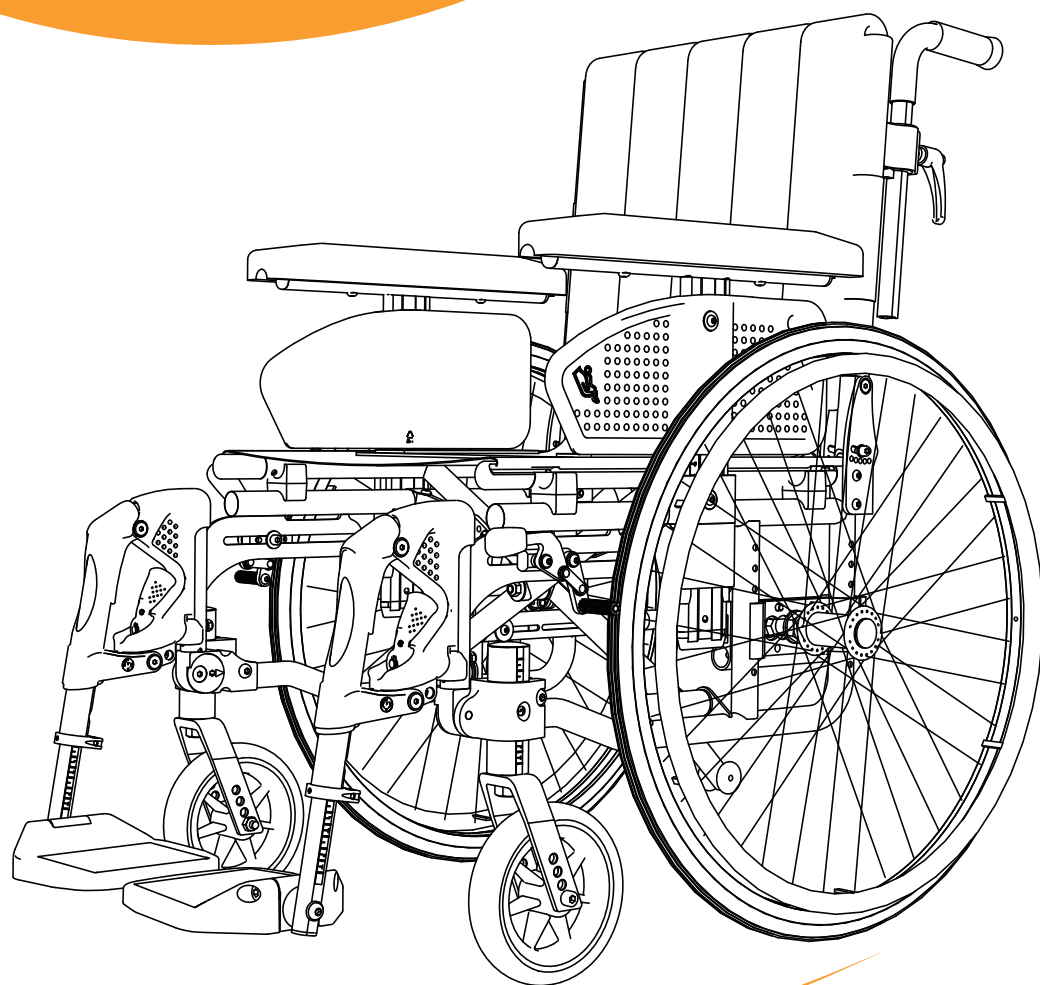

# User Manual



MB3150-GB



# Introduction

## **Congratulations on your choice of new wheelchair!**

Quality and function are key concepts for all wheelchairs in the Handicare series. Legend 2 is manufactured by Handicare Produksjon AS. Production takes place at Lillehammer in modern premises using high-tech equipment. With the production at Lillehammer we have excellent opportunities for influencing the design of the wheelchair models. We are extremely interested in feedback from you and your experiences with the wheelchair. Your feedback can help us to produce an even better product.

For your own safety, and in order to get the most out of your new wheelchair, we recommend that you read this user manual thoroughly before using the chair.

## **Handicare Legend 2 in brief**

Legend 2 has been developed in line with the market. The result is a unique wheelchair with quality comfort and good rolling properties. A total width of the seat width + 18 cm provides good ability to negotiate obstacles through narrow doors and in narrow rooms. Legend 2 is easy to take in the car or transport in other ways. The standard chair weighs only 17.9 kg and is only 28 cm wide when folded up.

Legend 2 is easy to adapt for the individual user. Many different adjustments can be made and the adjusting procedures are intuitive and demand a minimal use of tools and replacement of parts. Measuring scales on all adjustment points simplify the adjustments and make them accurate. In a few minutes for example you can adjust the height and tip over point in 25 driving wheel positions.

This user manual is for Handicare Legend 2  
with serial number: .....

The wheelchair was inspected and approved  
on: .....

by: .....



**Handicare produksjon AS**  
**Serviceboks**  
**2626 Lillehammer**  
**Norway**

[www.Handicare.com](http://www.Handicare.com)

# Contents

<b>Introduction.....</b>	<b>2</b>
<b>Contents .....</b>	<b>3</b>
<b>The wheelchair's parts .....</b>	<b>4</b>
<b>Assembly and transport .....</b>	<b>5</b>
<b>Using the wheelchair.....</b>	<b>6</b>
<b>Adjusting the chair .....</b>	<b>12</b>
<b>Positioning belt .....</b>	<b>23</b>
<b>Safety .....</b>	<b>24</b>
<b>Safety in cars .....</b>	<b>25</b>
<b>Maintenance.....</b>	<b>28</b>
<b>Technical specifications .....</b>	<b>31</b>
<b>Labelling.....</b>	<b>33</b>
<b>Accessories .....</b>	<b>34</b>
<b>Guarantee.....</b>	<b>36</b>

# The wheelchair's parts

In order to be able to read and understand this manual it is important that you familiarise yourself with the most common terms we use for the different parts of the wheelchair.

Have a look at the following drawing and note the relevant parts on your wheelchair.

The equipment on your wheelchair may vary somewhat from the illustration below.

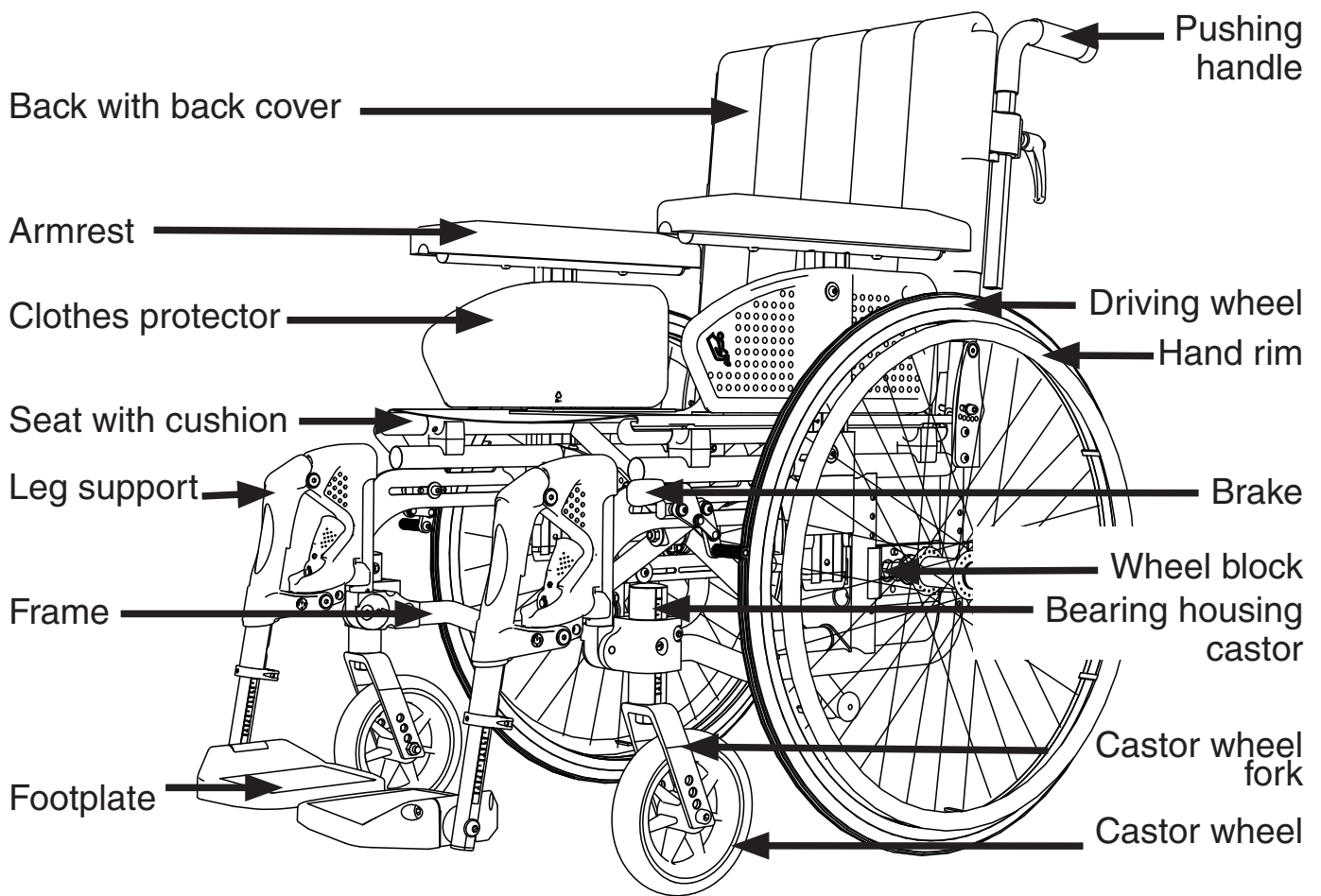

Figure 1

# Assembly and transport

## Assembly *Figure 2*

The standard version is delivered complete. All you need to do is unfold the wheelchair and fit the leg supports where necessary.

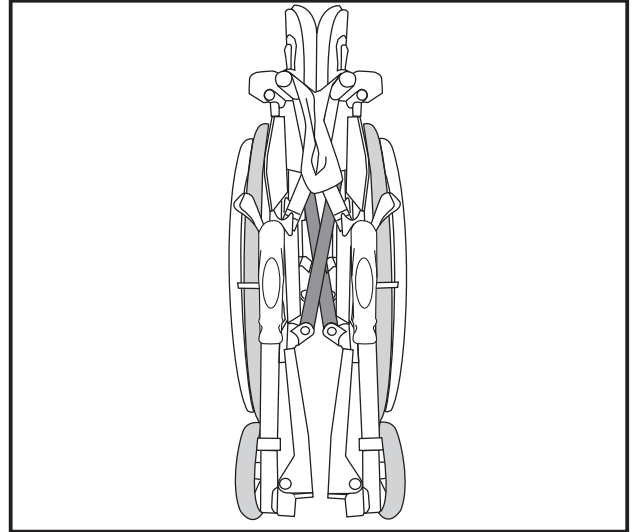

Figure 2

## Unfolding the wheelchair

### *Figure 3*

To unfold the wheelchair, press down with the flat of your hand on the cover by the seat tubing.

NB

Do not hold around the seat tubing as your fingers can get caught.

Put the seat cushion (accessory) into position ensuring that it sits properly on the seat fabric.

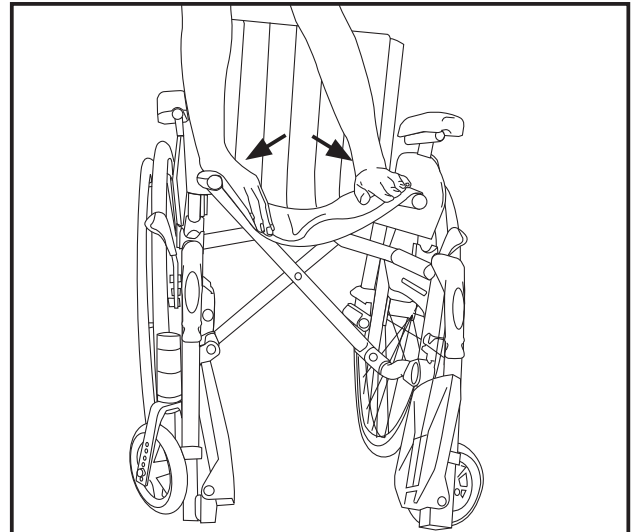

Figure 3

## Folding the wheelchair *Figure 4*

Remove the seat cushion (accessory) and pull up the footplates or remove the leg supports before folding the wheelchair.

Take hold of the seat cover and lift straight up.

The chair will fold together. Check that the back cover has folded backwards.

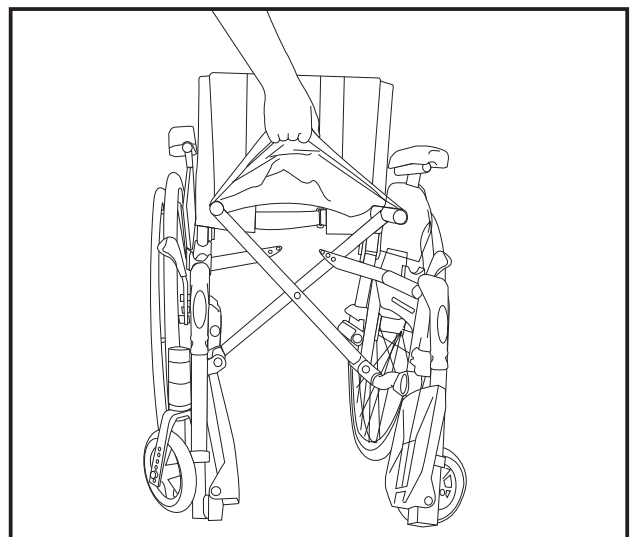

Figure 4

# Using the wheelchair

## Quick-release *Figure 5*

The wheelchair has a quick-release catch on the driving wheels. Press the button in the middle of the driving wheel in order to remove or attach the wheel.

NB

Check that the wheel is properly secured by ensuring that the button pops out approximately 5 mm when the wheel bolt is completely in the casing.

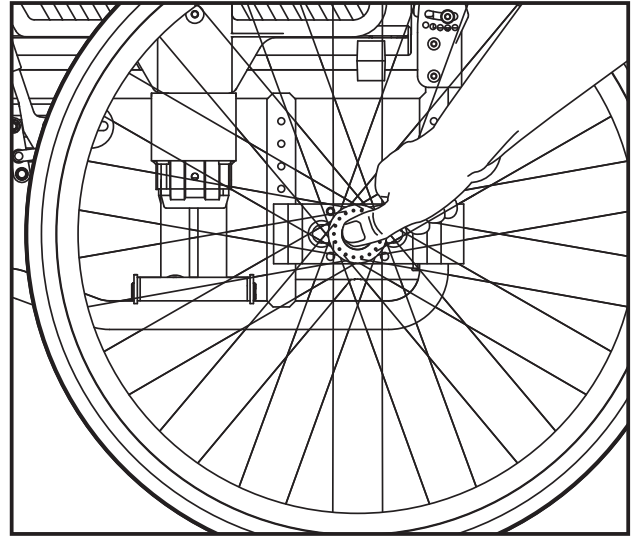

Figure 5

## Height adjustable pushing handle *Figure 6*

The pushing handle is adjusted by loosening the locking handle whilst moving the pushing handle upward or downward to the desired height. Re-tighten the locking handle.

You can remove the pushing handle completely by loosening the locking handle, pulling together the spring pin (6A) and pulling up the pushing handle.

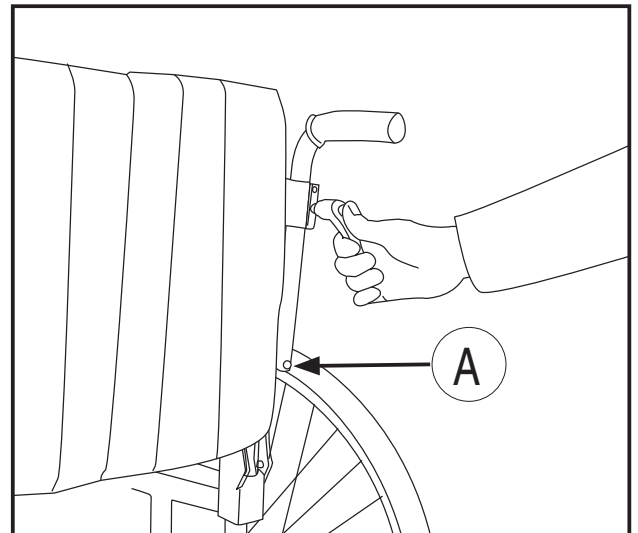

Figure 6

## Armrests, removing and fitting *Figure 7*

The armrests can be removed by lifting them straight up.

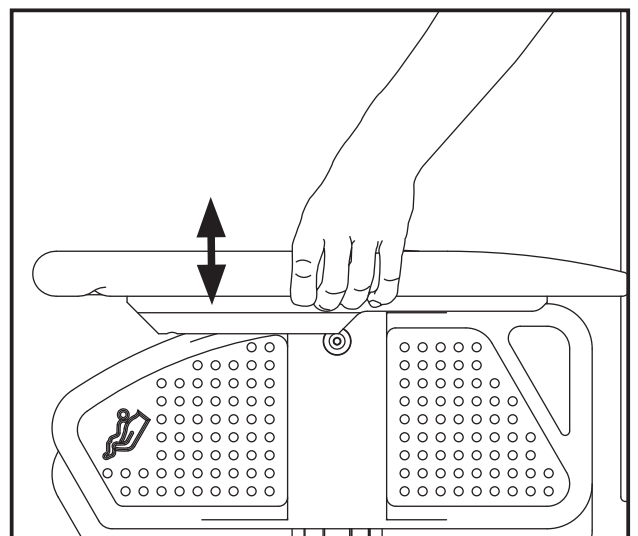

Figure 7

# Using the wheelchair

## Swing out/Attach/Remove the leg supports *Figures 8 and 9*

The leg supports can be swung in/out and removed for easier movement.

The supports can be released by twisting the handle (8A) inwards or outwards when the leg support is swung.

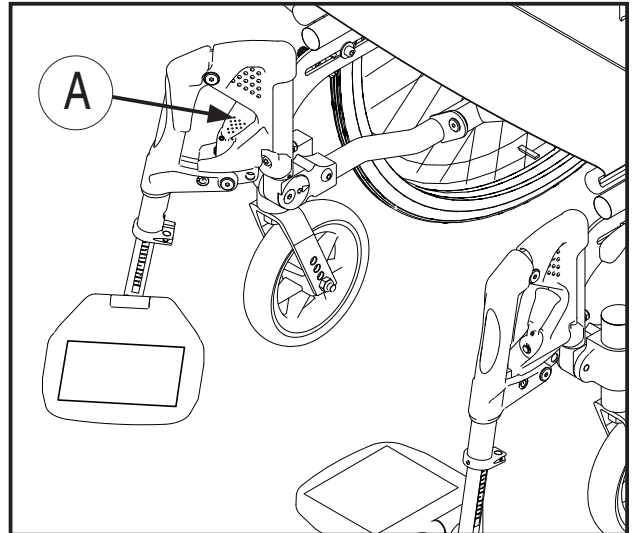

Figure 8

After the leg support has been swung to the side, it can be lifted straight up and completely removed if desired. In order to attach it again, carry out these steps in reverse order, and the handle will automatically lock.

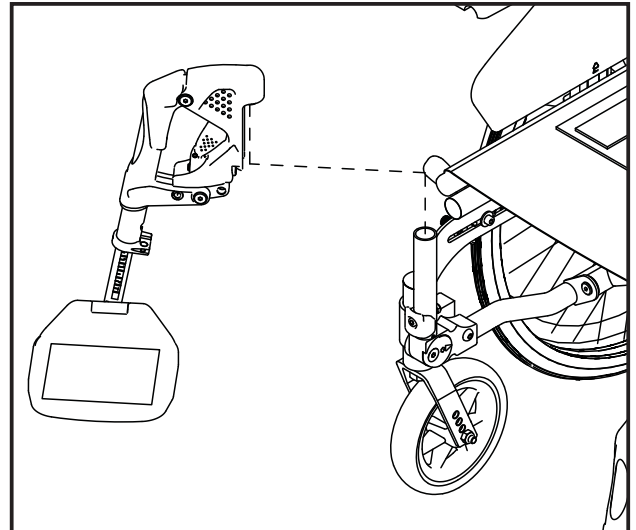

Figure 9

# Using the wheelchair

## Full footplate (Standard on XL chairs) *Figure 10*

The full footplate can be split in two and tipped up for transfers. Ensure that the footplates lock in place when you put them back down.

The footplates lock most easily into place if they are angled right in to each other when you put them back down (see figure 10).

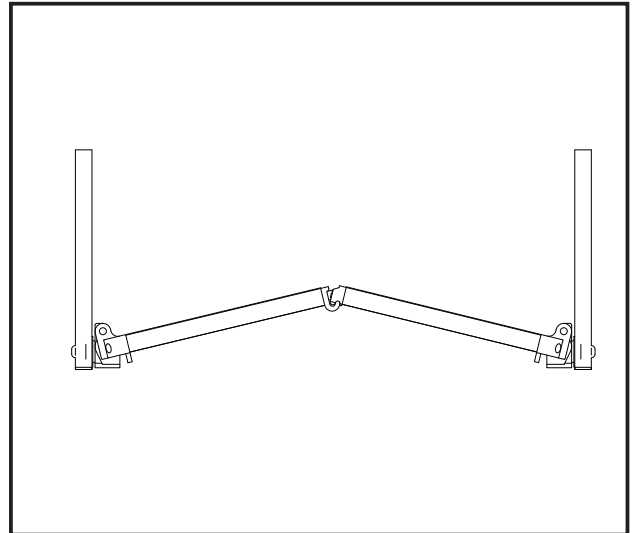

Figure 10

## Swing out/Attach/Remove the leg supports (Full footplate)

*Figures 11 and 12*

The leg supports can be swung in/out and removed for easier movement.

The supports can be released by twisting the handle (11A) inwards or outwards when the leg support is swung.

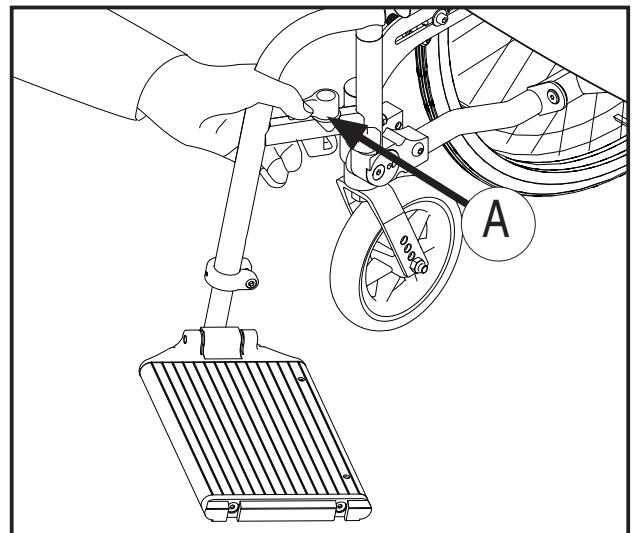

Figure 11

For an easier grip on the release handle, the starting position of the handle can be changed. Hold on tight to the lower part of the release handle whilst lifting the handle itself. Turn the handle to the desired position and release.

After the leg support has been swung to the side, it can be lifted straight up and completely removed if desired. In order to attach it again, carry out these steps in reverse order, and the handle will automatically lock.

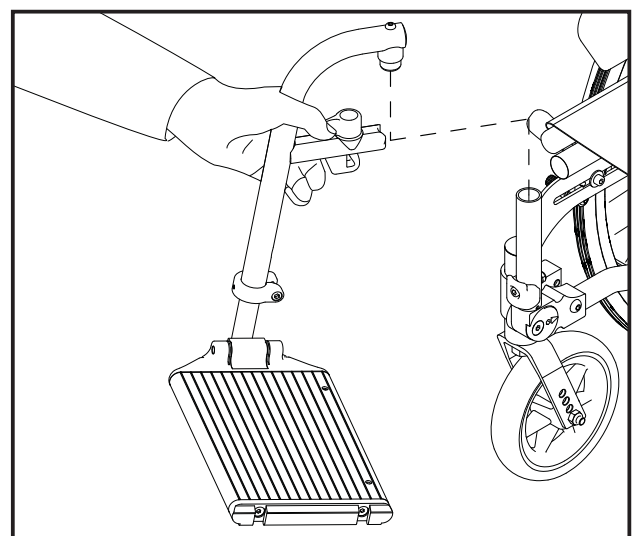

Figure 12



# Using the wheelchair

## Using the brakes *Figure 13*

Push the brake lever forward and down when you want to lock the brake.



The brake is only designed to hold the chair when it is stationary. Under no circumstances should it be used as a driving brake.

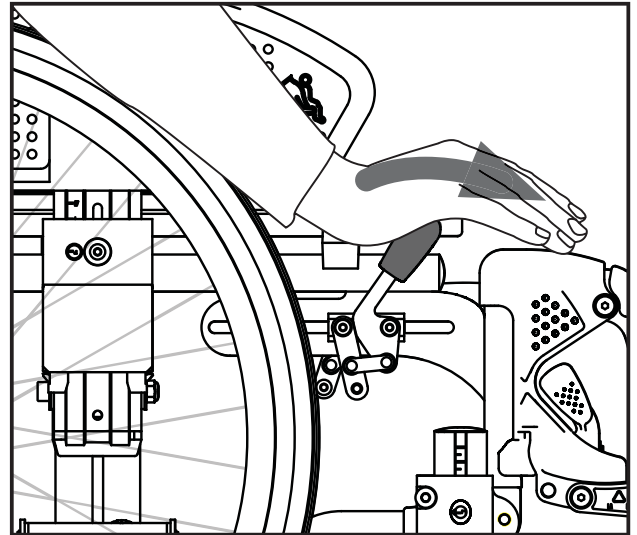

Figure 13

## Anti-tip stabiliser/Tipping bar

*Figure 14*

The anti-tip stabiliser is put into position by pulling it down and turning it in a downward direction simultaneously. The anti-tip stabiliser is adjusted as standard with a clearance to the base that makes it possible to negotiate door thresholds etc.

The tipping bar is accessible when the anti-tip stabiliser is up or down.

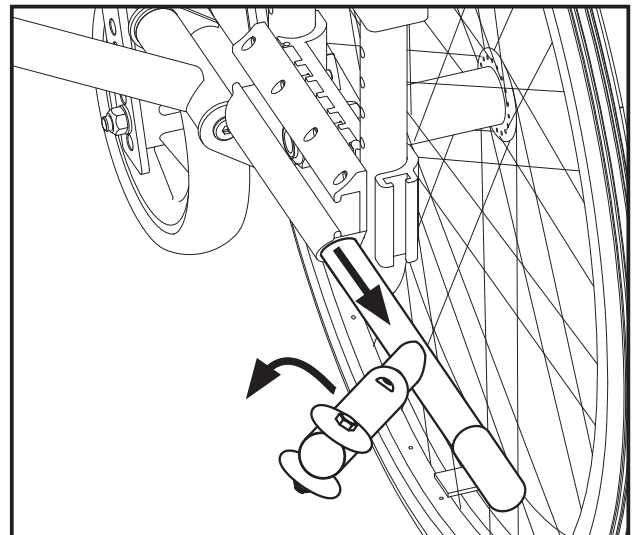

Figure 14

# Using the wheelchair

## Moving in and out of the chair

Figures 15, 16 and 17

- Activate the brakes
- Swing the leg supports away, where applicable
- Sit far forward on the chair before moving to another chair, bed etc.

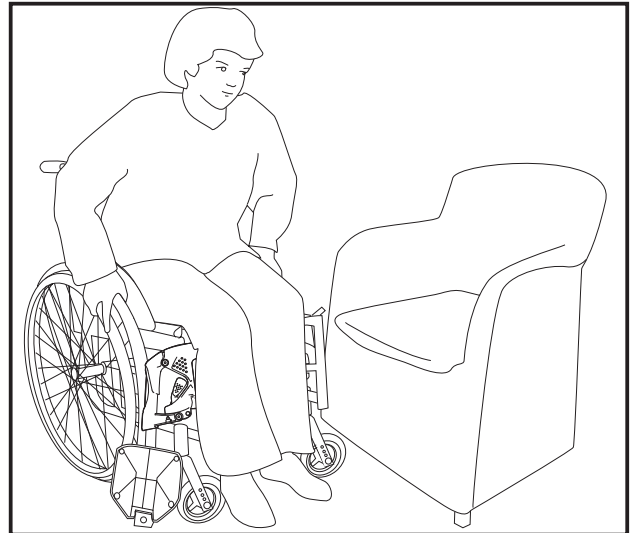

Figure 15

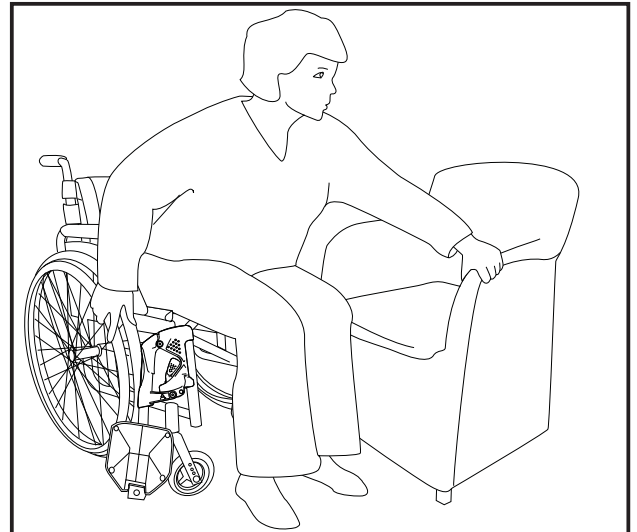

Figure 16

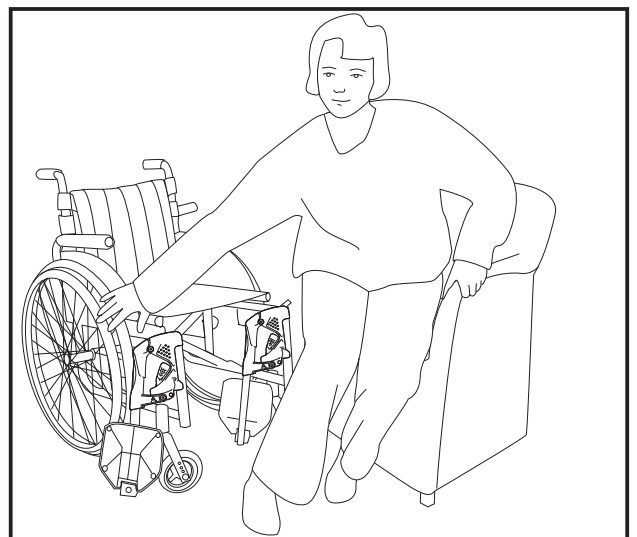

Figure 17

# Using the wheelchair

## Negotiating obstacles, stairs

Figures 18 and 19

If the wheelchair is being lifted up/down stairs with the user sitting in it, the recommended lifting points should be used. These are marked on the product.

The lifting points are the pushing handles and the leg supports.

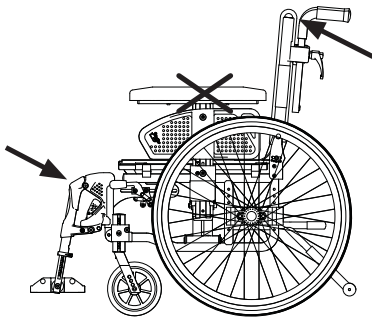

Do not lift the wheelchair by the armrests!

NB For height adjustable pushing handles, ensure that the handle is locked before lifting.

In order for assistants to have a better lifting position they can alternatively lift from each side of the chair.

## Negotiating obstacles, the kerb

Figure 20

When negotiating the kerb etc., swing the anti-tip stabiliser up. Then place one foot on the tipping bar whilst steering with the pushing handles.

### Steep terrain

For frequent use in undulating terrain, we recommend that a separate brake be fitted for the assistant.

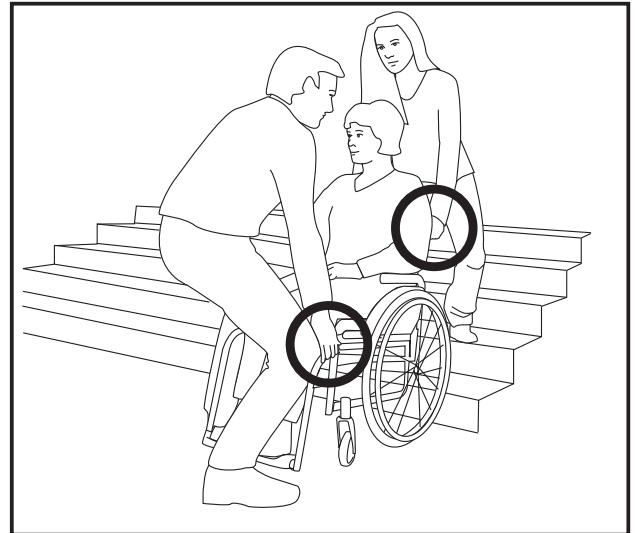

Figure 18

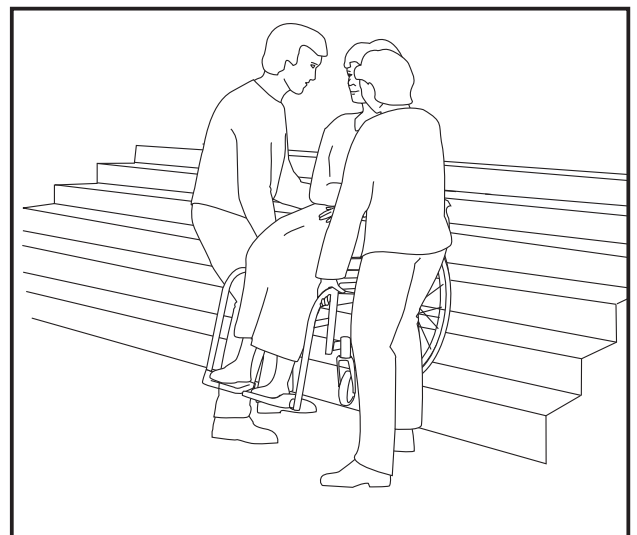

Figure 19

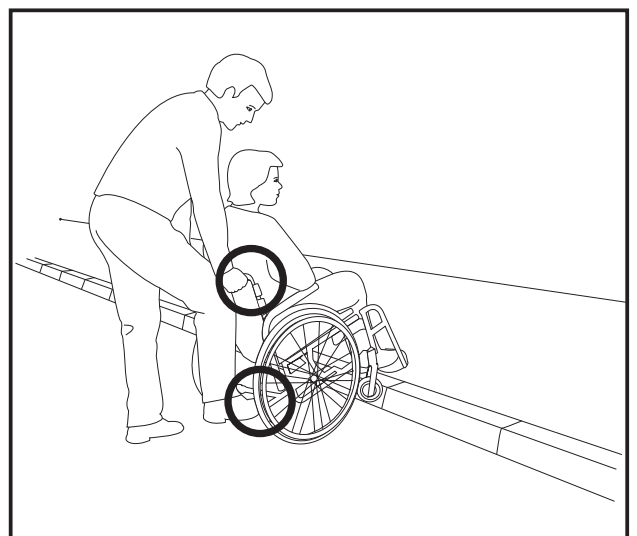

Figure 20

# *Adjusting the chair*

## **Legend 2 has measuring scales that help you to adjust the chair accurately**

The following adjustments can be carried out quicker and more accurately using the different measuring scales:

- **Seat height – back** Page 12 and 14  
The scale shows the seat height in relation to the driving wheels.
- **Centre of gravity** Page 16  
The measuring scale is numbered from 1 to 5, with 1 as the best anti-tipping position.
- **Seat height – front** Page 12, 14 and 17  
Stepless scale from 1 to 9 to ensure equal adjustment on both castor wheels.
- **Angle of castor wheels** Page 17  
Stepless scale to ensure equal adjustment on both castor wheels.
- **Back height** Page 18  
The scale shows the back height from 35 cm to 45 cm.
- **Back angle** Page 18  
The scale shows the back angle from  $-5^{\circ}$  to  $16^{\circ}$ .
- **Anti-tip stabiliser** Page 20  
The measuring scale is numbered from 1 to 5, in order to adjust the anti-tip stabiliser in relation to the driving wheel position.
- **Leg support length** Page 20  
Stepless scale from 1 to 9 to ensure equal adjustment on both leg supports.
- **Armrest height** Page 22  
The scale shows the distance from the seat to the top of the armrest. From 18 cm to 24 cm for standard armrests and 22 cm to 29 cm for high armrests.

# Adjusting the chair

## Adjusting the seat height

The seat height can easily be adjusted. You can also change the angle of the seat by having different heights at the front and back. By changing the angle of the seat, you can achieve better stability and seating comfort. The different seat height adjustments also effect the ability to negotiate obstacles and rolling properties of the wheelchair.

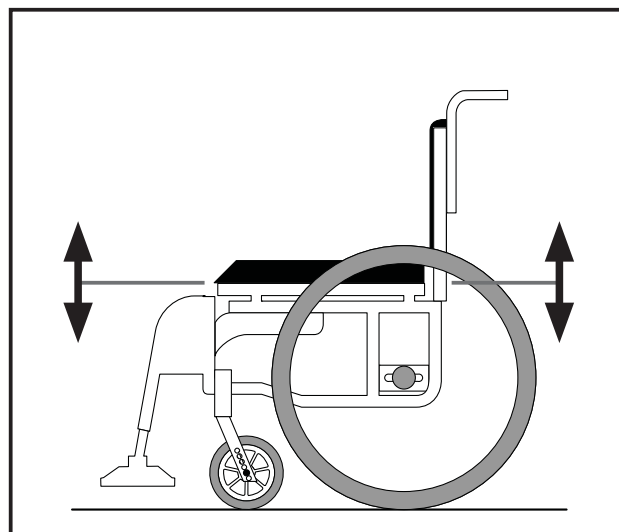

Figure 21

## Adjusting the seat height – back

*Figures 21 and 22*

The seat height at the back can be adjusted using the methods below.

Moving the wheel block up or down  
Moving the wheel block up, lowers the seat. Moving the wheel block down, raises the seat. See page 15.

Changing to bigger or smaller driving wheels

A bigger driving wheel increases the seat height, whilst a smaller wheel decreases the height. The table on page 31 shows which seat heights can be achieved by changing to different sizes of driving wheel.

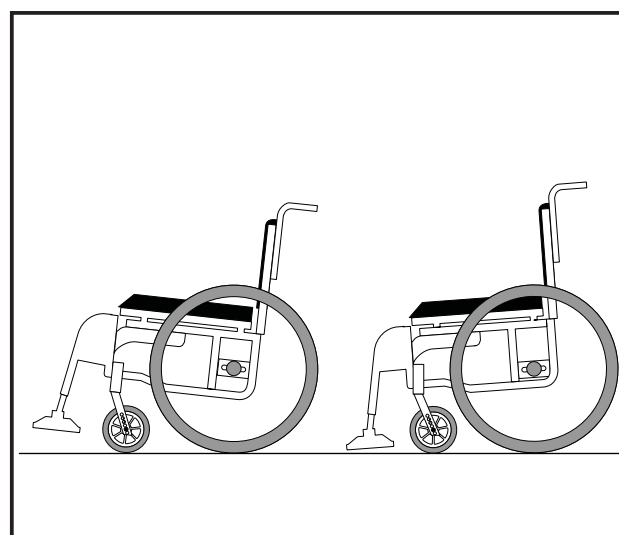

Figure 22

## Adjusting the seat height – front

*Figures 22 and 22*

The seat height at the front can be adjusted using the methods below.

Moving the bearing housing of the castor wheel up or down (see page 17).  
By moving the bearing housing up, the seat is lowered, and by moving it down, the seat is raised.

## Adjusting the chair

Moving the castor wheel to a higher or lower position in the castor wheel fork. By moving the castor wheel to a higher position in the castor wheel fork (23A), the seat is lowered, and by moving the castor wheel to a lower position, the seat is raised.

### Changing to bigger or smaller castor wheels

A smaller castor wheel lowers the seat height, whilst a bigger castor wheel raises the seat height. By changing the castor wheel, a smaller castor wheel will give a smaller turning radius, and thereby increase the ability to negotiate obstacles in narrow spaces, and will also give more room for the legs. A larger castor wheel will increase the turning radius but will also improve the ability to negotiate obstacles on uneven surfaces.

### Changing to a longer or shorter castor wheel fork

A shorter castor wheel fork lowers the seat height, gives a smaller turning radius, and thereby increases the ability to negotiate obstacles in narrow spaces, and will also give more room for the legs. A longer castor wheel fork increases the seat height, and allows several alternative castor wheels to be used.

The table on page 31 shows which seat heights can be achieved by using the methods above.

NB Remember to adjust the angle of the castor wheel when changing the seat height, and to adjust the brakes when changing the seat height at the back.

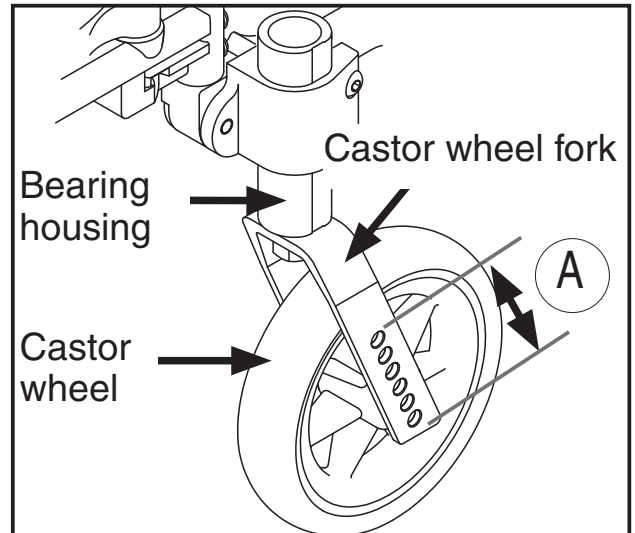

Figure 23

# Adjusting the chair

## Adjusting the seat height – back

Figures 24 and 25

On the wheelchair frame you will find a measuring scale (25A) showing the seat height in relation to the size of the driving wheel

- Remove the driving wheel
- Loosen the screw (25B) with a 27 mm wrench and unscrew until it stops
- Pull the inner and outer wheel block slightly apart
- Adjust the wheel block step-by-step up or down in accordance with the scale
- Squeeze the inner and outer wheel block together

### NB

- It is important to ensure that the pins in the wheel block go into the holes in the frame and that the casing lies horizontally in the track before tightening the screw.

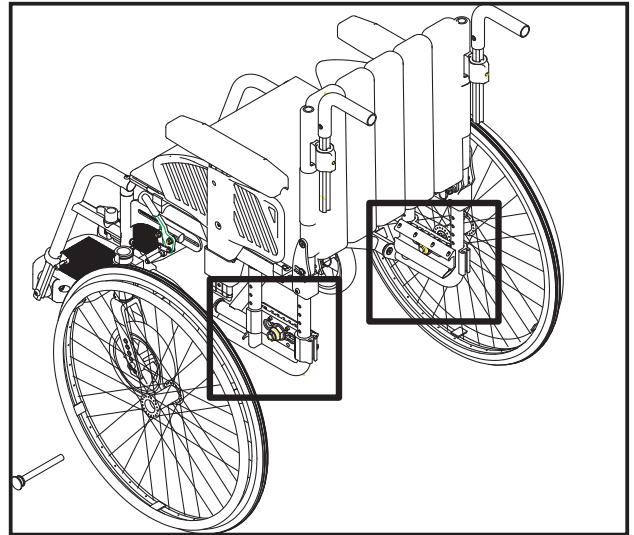

Figure 24

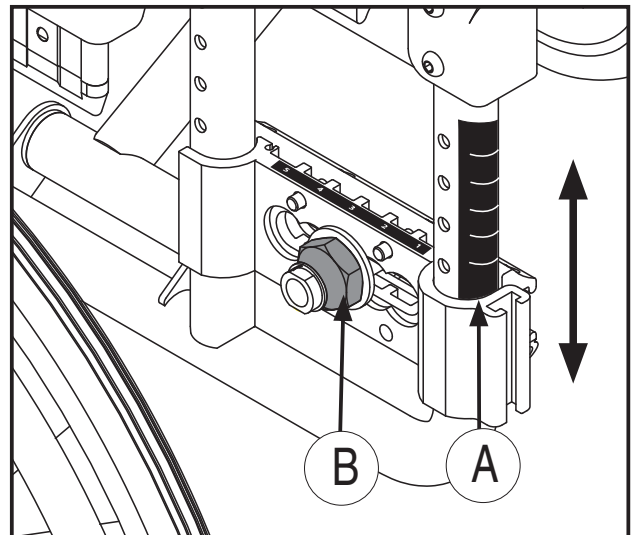

Figure 25

Alternative driving wheel dimensions		
24	22	20
40	38	36
42	40	38
44	42	40
46	44	42
48	46	44

Seat heights that can be achieved by the different steps on the scale

Find the dimension of your driving wheel at the top of the scale. The column under the wheel dimension shows where to place the wheel block in order to achieve the various seat heights.



# Adjusting the chair

## Adjusting the centre of gravity

Figures 26 and 27

The driving wheel can be adjusted to five different positions in relation to the centre of gravity.

This is shown on the scale (26A) on the wheel block. Position 1 represents the best anti-tipping position.

- Loosen the screw (26B) with a 27 mm wrench, and unscrew until it stops.
- Adjust the casing of the driving wheel forward or backward (Figure 27).

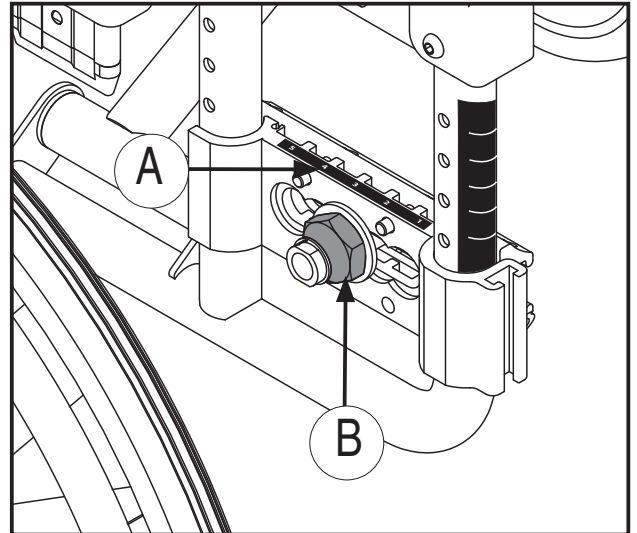

Figure 26

### NB

It is important to ensure that the pins in the wheel block go into the holes in the frame and that the casing lies horizontally in the track before tightening the screw.



Remember to adjust the brakes and the anti-tip stabiliser after you have adjusted the seat height and centre of gravity.

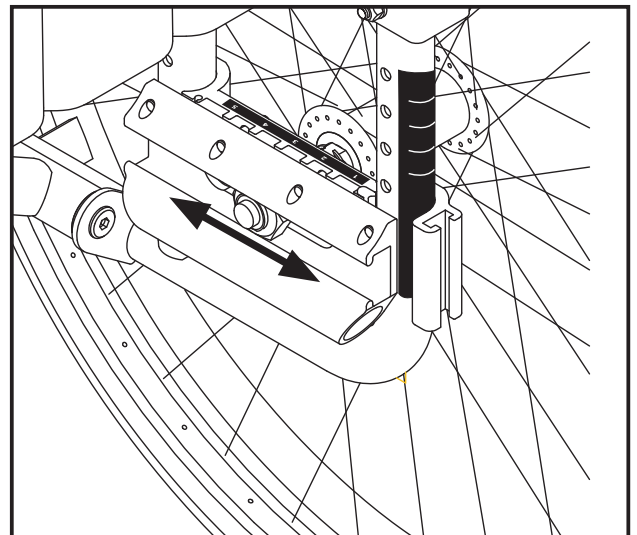

Figure 27

### NB

When changing the height and centre of gravity, the driving wheels should be adjusted first, followed by the height and angle of the castor wheels.



# Adjusting the chair

## Adjusting the seat height - front

Figures 28, 29 and 30

When adjusting the height of the wheelchair, the height of the driving wheels should be regulated before the angle. There is a scale for adjusting both the height and angle of the castor wheels, which helps to achieve equal measurements on both castor wheels.

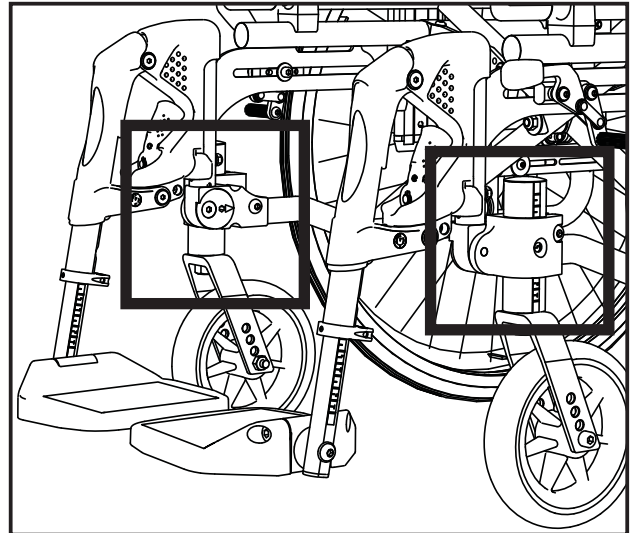

Figure 28

## Adjusting the castor wheel height

Figure 29

The driving wheel has a scale from 1–9 to help achieve the same height on both castor wheels.

- Loosen screw (29A)
- Adjust to the desired height, see scale (29B)
- Re-tighten the screw

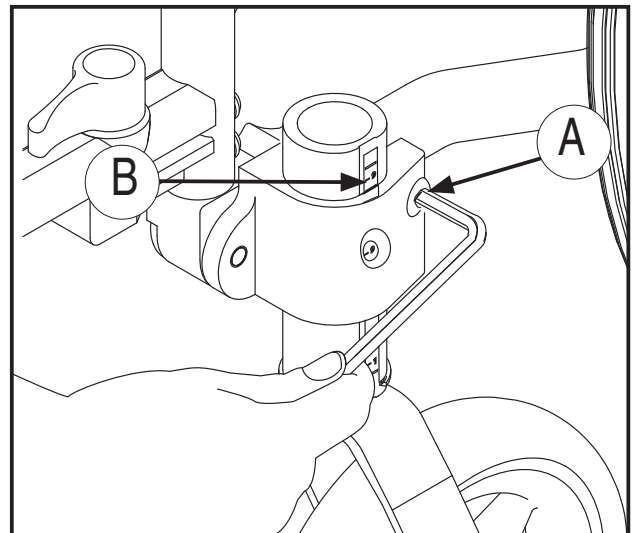

Figure 29

## Adjusting the angle of the castor wheel

Figure 30

- Loosen screw (30A) slightly
- Loosen screw (30B)
- Place the Allen key into the rotating disk (30C) and rotate to the desired angle. See the scale
- Tighten screw (30B). A screw locking device such as Blue Locktite, no. 243, can be used.
- Tighten screw (30A)

When the front castor wheel is at the correct angle, the bearing housing will be in a vertical position (90°) to the base. This is achieved by using a right angle to the bearing house/floor. The bearing housing level for achieving the correct angle can be supplied as an accessory (see page 34).

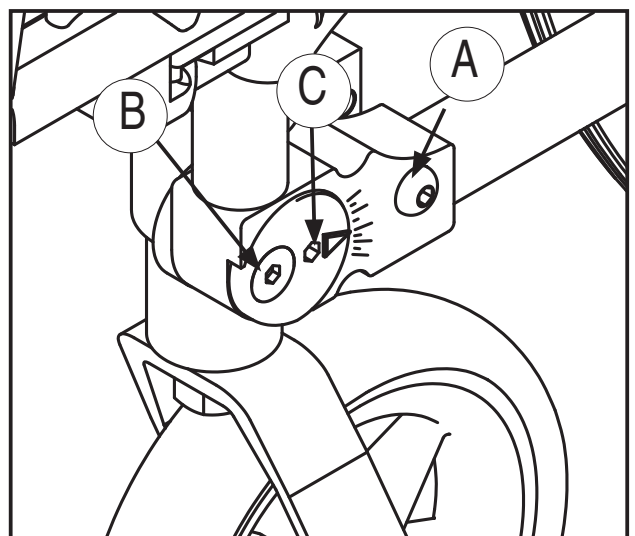

Figure 30

# Adjusting the chair

## Adjusting the height of the back

Figure 31

In order to access the back tubing when adjusting the back height, open the “lid” (C) in the back cover. The measuring scale (31A) shows the back height. For easier access to the back tubing, raise the pushing handle. The adjustment can be made whilst the user is in the wheelchair. Additionally, it is not necessary to remove the driving wheels in order to adjust the back height.

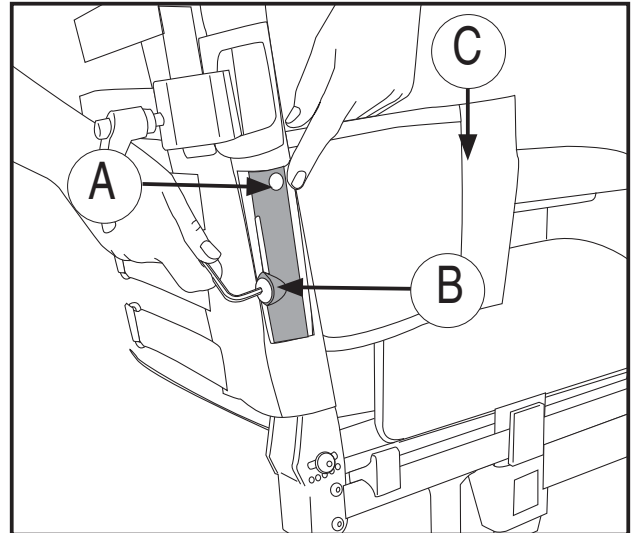

Figure 31

- Loosen the screw in the back tubing (31B)
- Adjust to the desired back height. See the measuring scale
- Re-tighten the screw

## Adjusting the angle of the back

Figures 32 and 33

The angle of the back can be adjusted from  $-5^{\circ}$  to  $15^{\circ}$ , in intervals of  $5^{\circ}$ . The scale showing the back angle (33A) is located on the back fitting bracket. The adjustment can be made whilst the user is sitting in the wheelchair. Additionally, it is not necessary to remove the driving wheels in order to adjust the back angle.

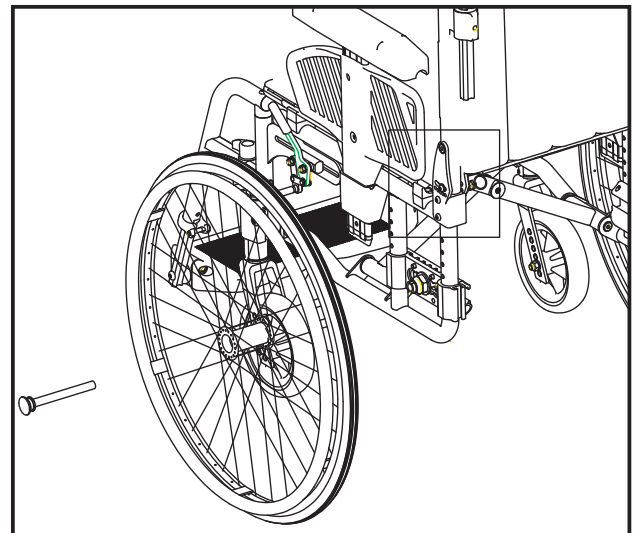

Figure 32

- Loosen screw (33B) approx. 5 mm
- Pull out the lock ring (33C), adjust the angle of the back and release the lock ring at the desired angle
- Re-tighten screw (33B)

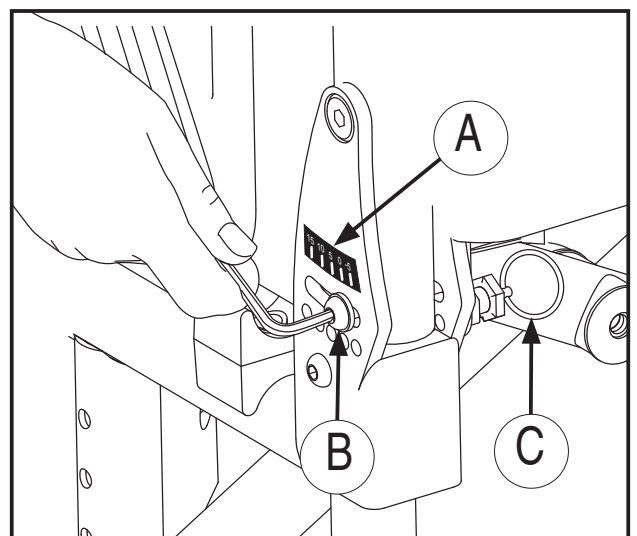

Figure 33

# Adjusting the chair

## Adjusting the curvature of the back *Figure 34*

The wheelchair has a padded back that can be adjusted to the curvature of the back in order to achieve a comfortable sitting position and good stability. The user can sit in the wheelchair when adjustments are being made for the curvature of the back.

Loosen the back cover in order to access the Velcro tapes. These can be adjusted to change the back curvature and so achieve maximum comfort and support.

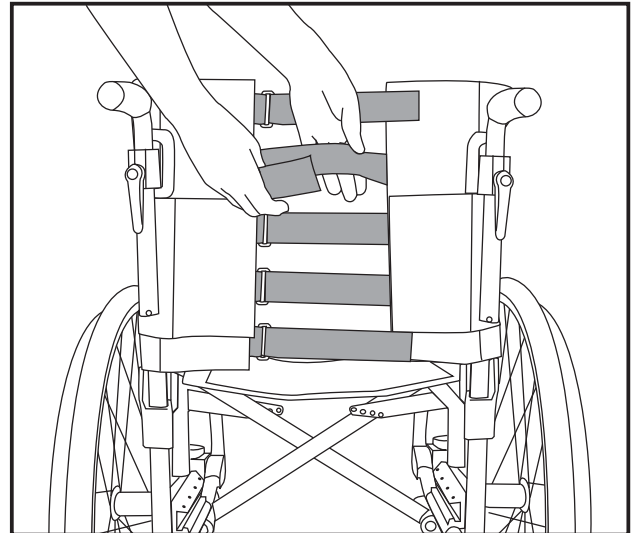

Figure 34

## Adjusting the brakes

*Figures 35 and 36*

The standard wheelchair is delivered with brakes that are fitted in the middle driving wheel position.

In order to move the brake, loosen the screw (35A) that is located on the inside of the frame at the front of the wheelchair. Move the entire brake in the track to the desired position. Correct distance between the brake block and the wheel (36A) is approximately 2.5 cm.

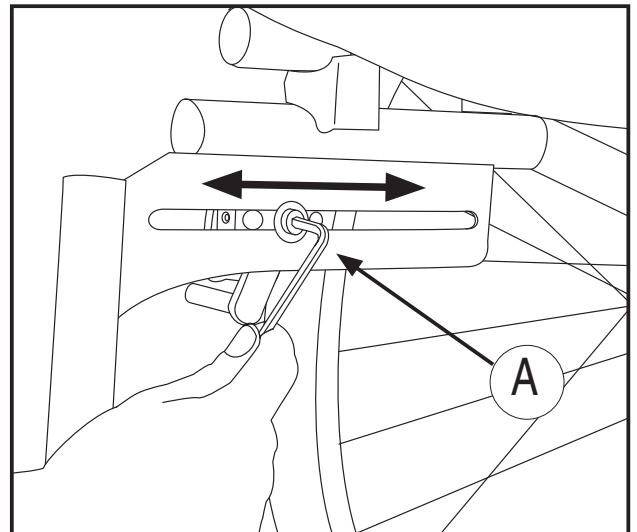

Figure 35

The brakes that are supplied with the wheelchair will not normally need to be adjusted.

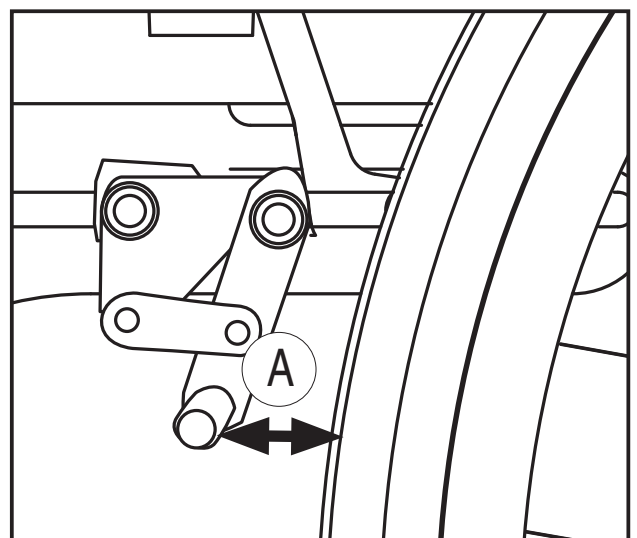

Figure 36

# Adjusting the chair

## Adjusting the anti-tip stabiliser

Figure 37

Adjust the anti-tip stabiliser when you have changed the centre of gravity of the wheelchair. Loosen screw (37A). Pull or push the anti-tip stabiliser to the correct position so that the measurement on the stabiliser's measuring scale corresponds to the driving wheel position. Re-tighten the screw. There should be a maximum of 37 mm from the end of the anti-tip stabiliser to the base. To adjust this, loosen the screw (37B) and push/pull the lower pipe of the anti-tip stabiliser. Re-tighten the screw.

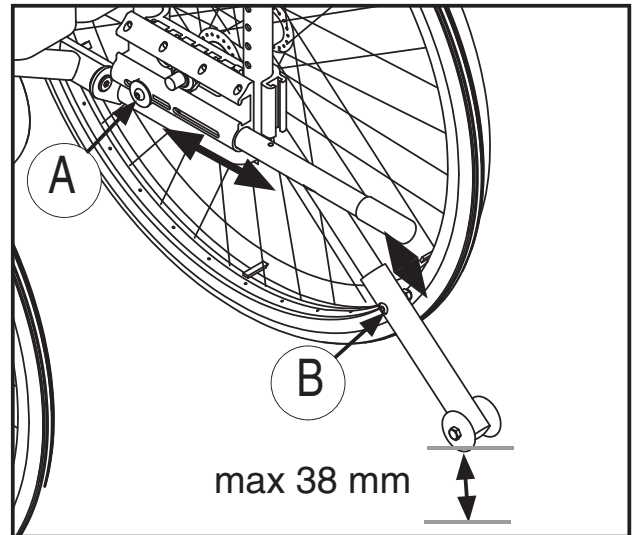

Figure 37

## Adjusting the length of the legrests

Figure 38

The leg supports have a linear scale (38A) on the outside, which helps to achieve the correct length. To adjust the length of the leg supports loosen the fixing screw (38B) approx. 5 mm. Then adjust the leg supports to the desired length and re-tighten the screw.

A quick-release catch for adjusting the leg supports is available as an accessory (see page 34).

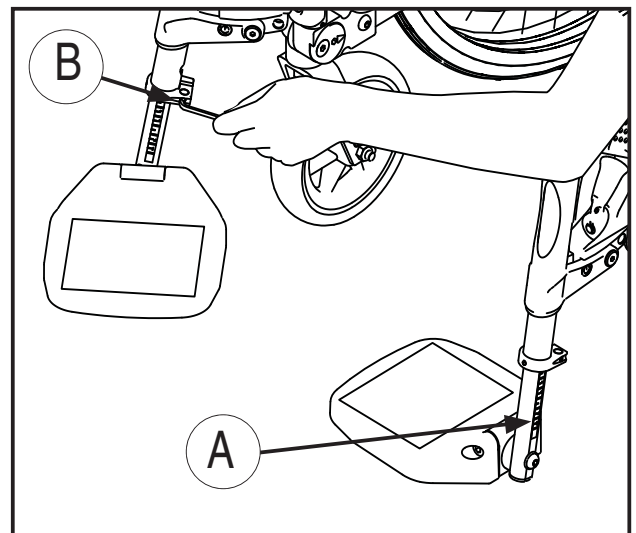

Figure 38

## Adjusting the angle of the legrests

Figure 39

The angle of the legrests can be adjusted to 70°, 80° or 90°.

- Remove the screw (39A)
- Pull or push the legrest to the desired angle
- Place the screw in the correct hole and tighten

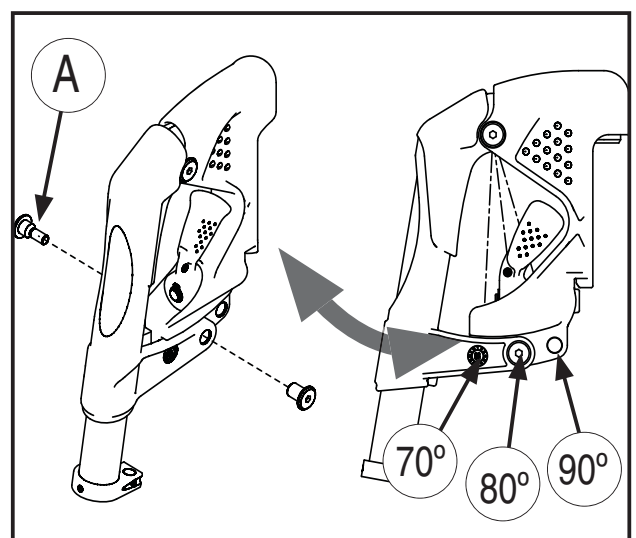

Figure 39

# Adjusting the chair

## Adjusting the seat depth

Figures 40, 41 and 42

The depth of the seat is adjusted with the help of the seat extension piece (41A). Seat extension pieces of 3 cm and 5 cm are supplied with the wheelchair. If the wheelchair is fitted with seat extension pieces, a plug (41B) is provided in place of one of the pieces.

The table on page 31 shows which seat depths can be achieved on your wheelchair.

*To extend the seat:*

Unscrew screw (40A) Remove the plug or seat extension piece at the front of the seat tubing. Loosen the overlapping Velcro in the seat fabric and pull the seat cover forward (42A). Place the plastic tube (3C) into the fold of the seat fabric inside the seat tubing. Assemble the seat extension piece (41A).

Insert the screws (40A) and tighten.

*To shorten the seat:*

Unscrew the screw (40A). Remove any seat extension pieces at the front of the seat tubing. Loosen the overlapping Velcro in the seat cover and pull the cover towards the seat back (42A). Insert the screws (40A) and tighten.

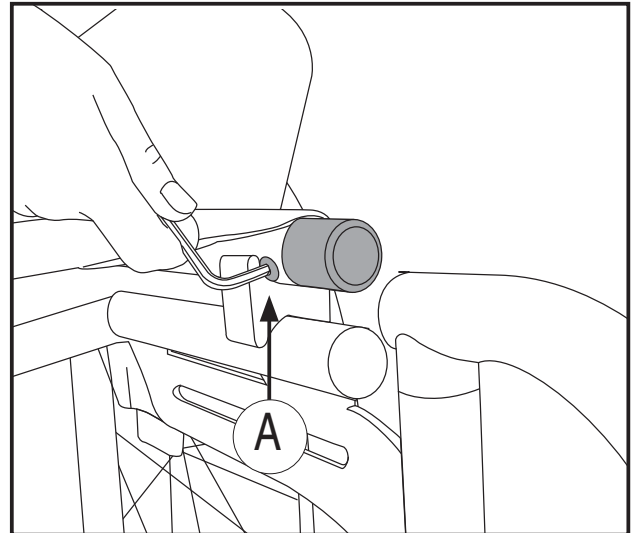

Figure 40

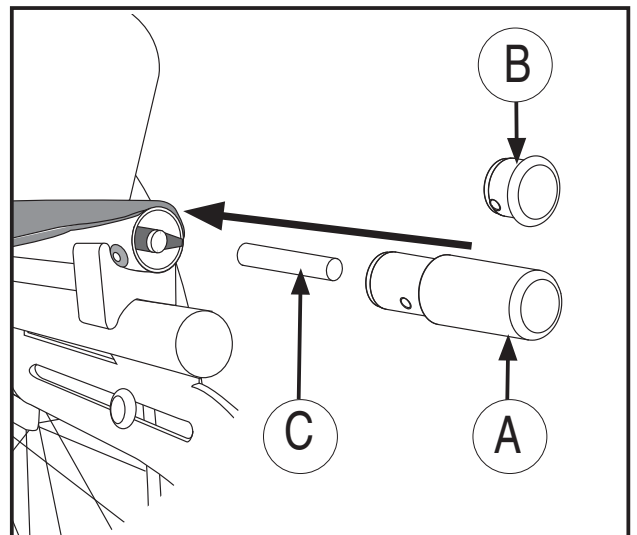

Figure 41

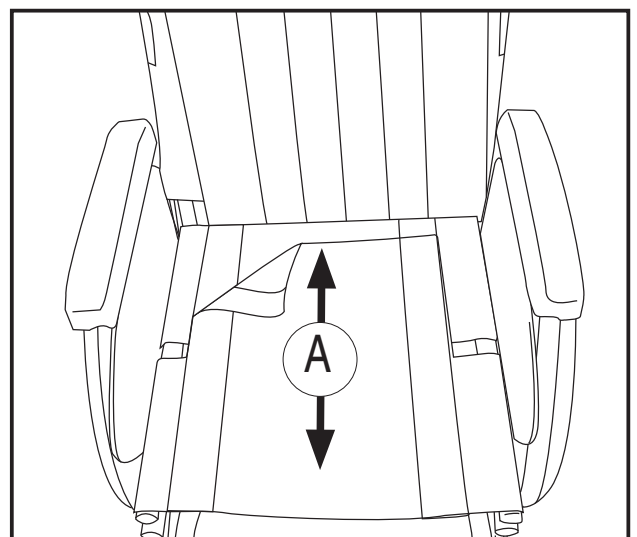

Figure 42



# Adjusting the chair

## Adjusting the height of the armrest *Figure 39*

In order to adjust the height of the armrest, loosen the screw (39A). Raise or lower the armrest to the desired position. Refer to the scale (39B) in order to achieve the same height on both armrests. The scale shows the number of centimetres from the seat to the top of the armrest. Re-tighten the screw. When the armrest is adjusted to the desired position, the clothes protector can be moved in order to avoid openings to the wheel. Loosen the screw (39C) and push the clothes protector up or down. Re-tighten the screw. (The clothing protector cannot be adjusted on Legend 2 in seat width 54–60.)

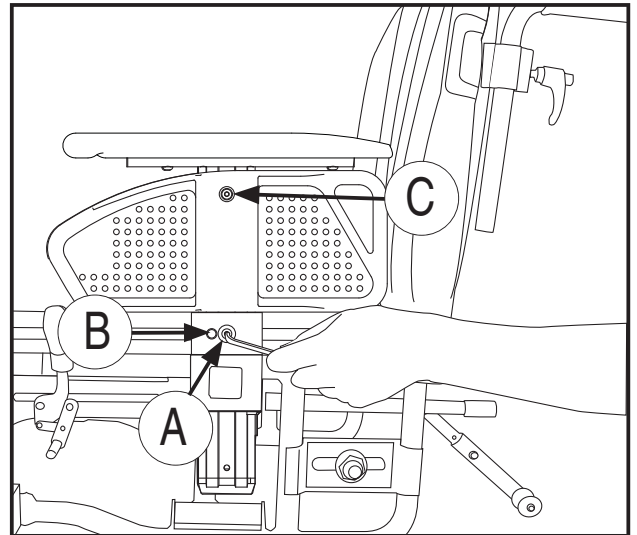

Figure 43

## Adjusting the depth of the armrests *Figure 44*

Adjust the depth of the armrests by moving the armrest pads forwards or backwards.

- Loosen the screws (44A) using a 10 mm wrench
- Push the armrest pads forwards/backwards to the desired position and tighten the screws

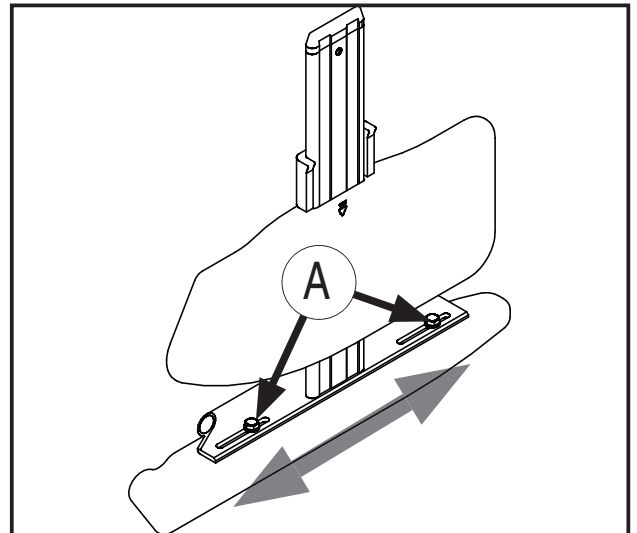

Figure 44

# Positioning belt

## Assembly instruction Positioning belt (accessorie)

Figures 43, 45 and 46

- Remove the screws (43A) with a 4 mm Allen key.

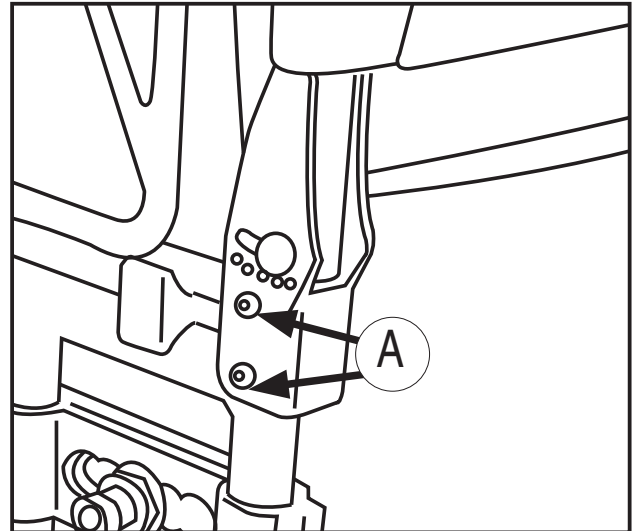

Figure 43

- Locate the fixing bracket as shown in figure 2. Fasten it with the screws you removed, or use the screws that came with the fixing brackets.

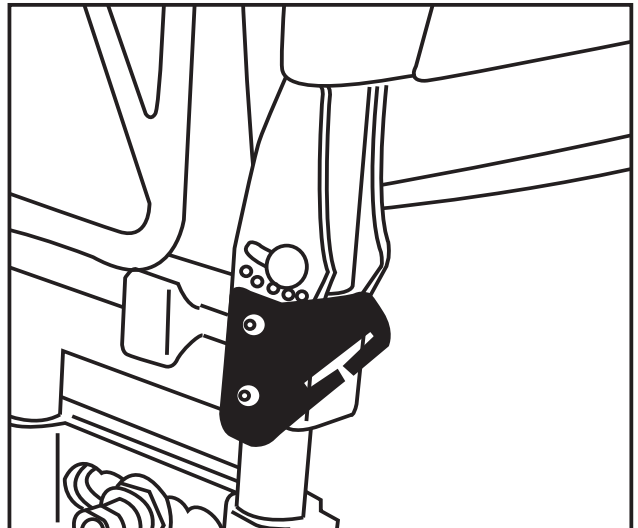

Figure 45

- Feed the lap belt through the slots in the fixing brackets.

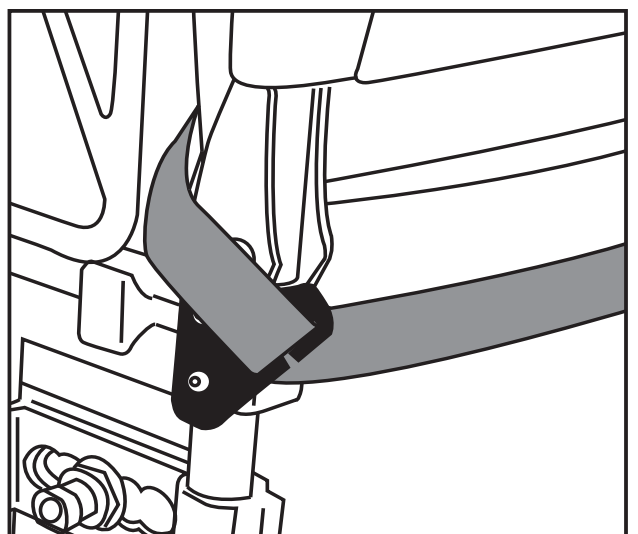

Figure 46

# Safety

- Do not stand on, or exert any great pressure on the footplates.
- A wheelchair should be regarded as a replacement for the walking function. Users must therefore travel among pedestrians, and not on roads or streets with traffic.
- When moving out of the wheelchair ensure that you are standing on as stable and even a surface as possible. In order to ensure that the wheelchair does not move at unwanted times, ensure that the brake is locked in position.
- The maximum weight capacity for Legend 2 is 135 kg.
- You should inspect the wheelchair regularly in order to ensure that all screws, bolts and other fastenings are properly secured.
- The wheelchair should not be used as a seat in motorised vehicles.
- When the wheelchair is in use, always ensure that the anti-tip stabiliser is activated.
- If the leg-support hanger has been removed from the chair, the accompanying protection for the front of the frame should be used to prevent injury to the user.
- When modifying the chair, such as moving the driving wheels, moving the castor wheels, changing the back height etc., the chair's handling properties, balance and tip over point can be affected. Special care should be taken when the wheelchair is put into use again.
- It is recommended that the user have a qualified helper when moving in and out of the chair.
- Ensure that clothing, baggage and other loose objects do not get caught in the spokes.
- Be aware of the potential risks of getting your fingers caught. Avoid putting fingers between the clothes protector and wheel, and between the wheel and brake.
- If it is necessary during operation to raise the chair's front in order to pass an obstacle, never do this by pressing the pushing handles down. Step on the tipping bar whilst applying moderate force to the pushing handles.
- If the user sits in the wheelchair for long periods at a time, the risk of pressure soars increases. Where there is a high risk of pressure soars we recommend that a special seat cushion be used to counteract this.



# Safety in cars

## Legend 2 as a passenger seat in a car

Where possible, the wheelchair user should be moved to the passenger seat of the car and use the car's seat belt.

The wheelchair can be used as a passenger seat in a car and has been tested in accordance with ISO 7671/19.

When the wheelchair is used as a passenger seat it should sit facing forward.

The wheelchair must be attached to the fastening system it was tested for;

Unwin WWR/ATF/K/R

User fastening: QIR/3H/ATF/FA/WH

The system is a 4-point fastening system. The system is a total system that fastens both the wheelchair and user to the car. The system requires fastening rails to be mounted in the car.

Legend 2 has marked off four points (Figure 46) that must be used when securing the wheelchair:

- The rear tubing of the side frame, above the wheel block
- The front tubing of the side frame, above the bearing housing

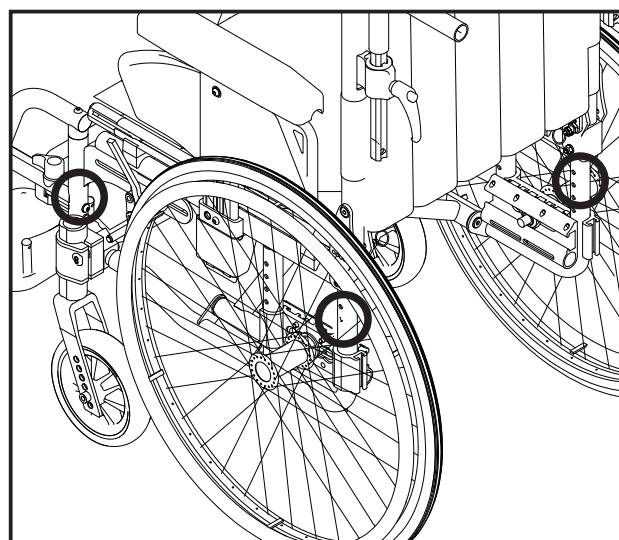



Figure 46

 When using Legend 2 as a passenger seat in a car, a neck support without a link for depth adjustment should be used.

 Handicare relinquishes itself of all responsibility in the event that Legend 2 is used as a passenger seat in a car using a different fastening system to the one mentioned above.

# Safety in cars

## Fastening the seat belt:

- The stomach belt must be fastened at as steep an angle as possible; between 30° and 75°
- The chest belt is fastened over the shoulder and chest
- The seat belt is fastened as tightly to the body as possible and must not be twisted
- Make sure the seat belt is not kept away from the body by the wheelchair parts, such as armrests and wheels. For correct positioning, see figure 47
- The chair must not be tilted backwards when used as a passenger seat in a car

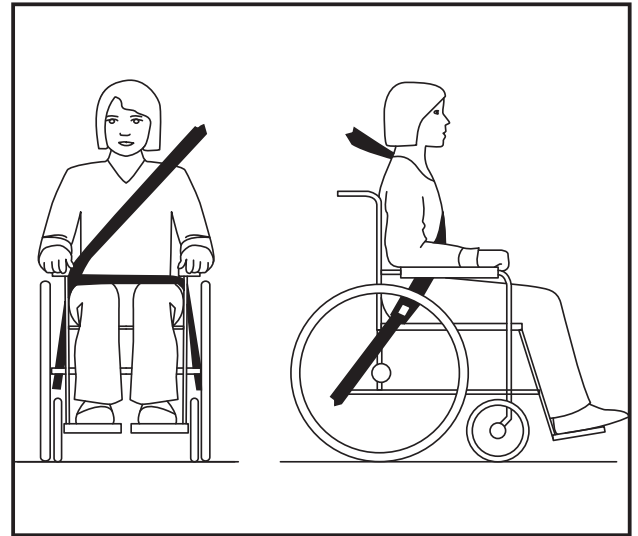

Figure 47



## WARNING

- a) Where possible, the wheelchair should be in a forward facing direction and secured in accordance with the instructions from the manufacturer of the fastening system.
- b) This wheelchair is approved for use in cars and meets the requirements for forward facing transport and head on collisions. The wheelchair has not been tested for other positions in a vehicle.
- c) The wheelchair has been dynamically tested in a forward facing direction, with the user secured by both a stomach and chest belt (3-point seat belt)

## *Safety in cars*

- d) Both the stomach and chest belts should be used to reduce the risk of head and chest injuries in the event of colliding with parts in the car.
- e) In order to reduce the risk of injury to the user, tables that are fitted to the wheelchair, which are not designed for crash safety, must be:
  - Removed and secured separately in the vehicle, or
  - Secured to the wheelchair, but with energy-absorbing padding placed between the table and the user
- f) Where possible, other wheelchair accessories should be secured to the wheelchair or removed from the chair and secured in the vehicle during transport, so that they don't become loose and cause injury to the user in the event of a collision.
- g) Support and positioning equipment must not be regarded as safety equipment/seat belts if they are not labelled in accordance with the requirements of ISO 7176/19-20XX.
- h) The wheelchair should be inspected by a representative of the manufacturer before being used again after any kind of collision.
- i) No changes or replacements must be made to the anchorage points/car fastenings on the wheelchair, or to constructional elements or parts of the frame without consulting the manufacturer.
- j) When using electric wheelchairs in motor vehicles, gel-filled batteries should be used.

# Maintenance

Maintenance covered in this section can be carried out by the user. Other maintenance work should be undertaken by the supplier's qualified personnel in your area or by the help centre. For information concerning repairs or service, please apply to the help centre in your county.

## Washing the frame

The frame should be washed regularly with mild soapy water. If the frame is very dirty, a scouring agent may be used. The frame can also be flushed using a high pressure jet spray. Spraying directly at the ball bearings using a high speed jet spray should be avoided. Dry the wheelchair thoroughly after washing or when it has been in the rain. If a scouring agent is used, movable parts should be re-greased.

## Cleaning seat and back covers

The seat cover, back cover and extra back cover can be washed at 60°C. See the washing instructions on the different materials.

## Conditions that can damage the wheelchair

The wheelchair should not be used in temperatures below -35°C or in excess of 60°. There are no restrictions with regard to humidity or atmospheric pressure. Storing the wheelchair does not require any special conditions in addition to the above.

## Screws and nuts

Screws and nuts can become loose over time. Remember therefore to check these at regular intervals and tighten where necessary. A screw locking device such as Blue Locktite, no. 243, can be used. After a lock nut has been removed, it loses some of its locking properties and should be replaced.

## Driving wheels

The driving wheels have spokes. These should be adjusted at least once a year. Apply to a local cycle dealer or to your nearest help centre.

## Quick-release catch on wheels

The quick-release catch on the driving wheels requires regular inspection. Check that the bearings work properly. The release bolt and bearings should be cleaned and greased with oil regularly.

# Maintenance

## Recommended air pressure

The wheelchair is delivered as standard with solid wheels. Find where the size is given on the driving wheel/castor wheel, then find the recommended maximum air pressure in the table. Note that high air pressure makes the wheelchair easier to roll, whilst lower air pressure gives more cushioning. For optimum handling properties, the air pressure should be checked regularly.

	<b>kPa</b>	<b>Bar</b>	<b>PSI</b>
Driving wheel air	350	3,5	50
Driving wheel high pressure	630	6,3	90
Castor 6" air	250	2,5	35
Castor 8" air	250	2,5	36

## Tools for service and maintenance of the wheelchair

<b>Adjusting:</b>	<b>Tools:</b>	<b>Adjusting:</b>	<b>Tools:</b>
<b>Brakes</b>	Allen key 4 mm	<b>Back height</b>	Allen key 4 mm
<b>Leg support length</b>	Allen key 5 mm	<b>Back angle</b>	Allen key 4 mm
<b>Footplates</b>	Allen key 5 mm	<b>Seat depth</b>	Allen key 3 mm
<b>Anti-tip stabiliser</b>	Allen key 4 mm, 5 mm, wrench 10 mm	<b>Seat height front</b>	Allen key 5 mm
		<b>Driving wheel pos.</b>	Wrench 27 mm
<b>Armrest height</b>	Allen key 4 mm	<b>Castor angle</b>	Allen key 5 mm

## Inspection after six months, subsequently every year

- Check that the brake works properly. Adjust if necessary.
- Check that the tyres are whole and that there is no damage to the sidewalls.
- Ensure that the wheelchair is clean and that all moveable parts work.
- Check for slack on the front castor wheel fork. Adjust if necessary. The axle should run freely around its axis, but there should not be any slack in an up/down direction.
- Check screwed joints and adjust where necessary.

## Repairs

Apart from minor enamel repairs, change of tyres, tubes and adjusting the brakes, all repairs must be carried out by the supplier's qualified personnel in your area or at the help centre.

For information regarding repairs or service, enquire at the help centre in your county.

# Maintenance

## Changing inflated tyres *Figure 48*

Inflated tyres are accessories.

### Dismounting tyres

- Remove the wheel, drain off the air by holding in the small pin in the valve, or by unscrewing the valve.
- Ensure that the edge of the tyre is positioned well into the inner groove of the rim (48A).
- Bend the edge of the tyre over the edge of the rim. Use a special tyre lever (48B) if necessary. Make sure that the tube does not get caught between the lever and the edge of the rim.

### Fitting tyres

- Insert the tube into the new tyre and apply a friction-reducing agent (tyre fitting agent or soap) to the end of the tyre (48C).
- Ensure that the end of the tyre is positioned well into the groove of the rim on one side. Bend the tyre over the edge. Ensure that the tube does not get caught.
- Fill the right amount of air pressure and fit the wheel to the wheelchair.

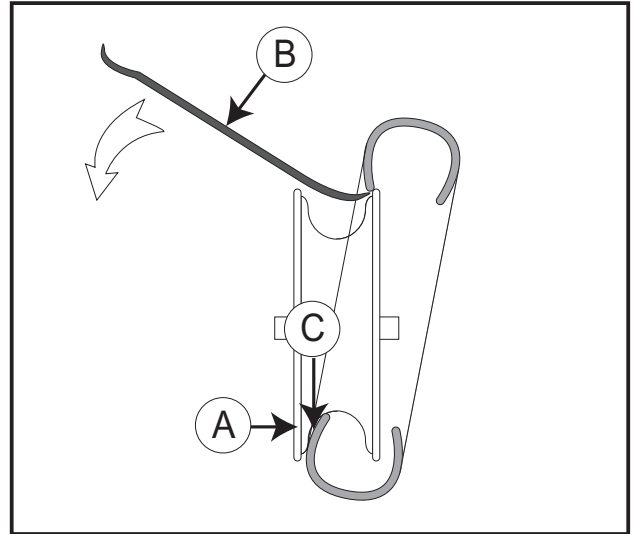

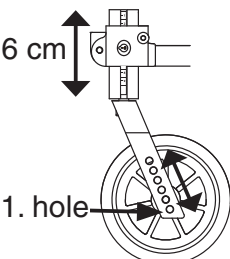

Figure 48

# Technical specifications

## Technical specifications and dimensions

The wheelchair is delivered as standard in several different seat heights and seat widths. The height that best suits the user of the wheelchair depends on two factors: The height of the user and how the wheelchair will be operated. Ask your dealer or enquire at your nearest help centre if you are uncertain as to whether you have the correct height and width. (Dimensions are given in centimetres unless otherwise specified.)

<b>Seat width</b>		36, 39, 42, 45, 48, 51, 54, 57 and 60							
<b>Seat depth</b>		<b>Standard</b>			<b>Long</b>				
		39			45				
		36 Seat cover back (-3 cm)			42 Seat cover back (-3 cm)				
		42 Seat extension piece (3 cm)			48 Seat extension piece (3 cm)				
		45 Seat extension piece (6 cm)			51 Seat extension piece (6 cm)				
<b>Seat height – front</b>		 = position not applicable							
<b>Fork</b> mm	<b>Wheel</b> inches/ mm	<b>Hole positions in the castor wheel fork</b>							
		1.	2.	3.	4.	5.	6.		
92	4"/100	37-43	35,5-41,5						
92	5"/125	38,5-44,5							
120	4"/100	40-46	38,5-44,5				37-43		
120	5"/125	41,5-47,5	40-46				38,5-44,5		
120	6"/150	43-49	41,5-47,5				40-46		
146	4"/100	43-49	41,5-47,5				40-46		
146	5"/125	44,5-50,5	43-49				41,5-47,5	40-46	
146	6"/150	46-52	44,5-50,5				43-49	41,5-47,5	
146	8"/200	47,5-53,5	46-52						
<b>Seat height back</b>		<b>Driving wheel</b>			<b>Seat height – back</b>				
		20"			36 - 44				
		22"			38 - 46				
		24"			40 - 48				
<b>Back height</b>		35 - 45							

## *Technical specifications*

<b>Armrests height</b>	Standard armrests 17 - 24
	Armrest height 22 - 29
<b>Total height</b>	75 - 93, Standard 84
<b>Total width</b>	Seat width +18
<b>Width folded up</b>	28
<b>Total length</b>	94 - 100, Standard 97
<b>Weight of chair</b>	18 kg
<b>Max. user weight</b>	140 kg (SW 54, 57 and 60: 160 kg)

The wheelchair and most of its fittings are manufactured in a special aluminium alloy. The back and seat covers are made of flame retardant material. The wheelchair can alternatively be delivered with solid/pneumatic tyres for the castor wheels and driving wheels.

### **Waste management**

Waste from packaging and parts of the wheelchair, as well as the wheelchair itself, can be treated as ordinary waste. The main constituent of the wheelchair is aluminium, which is suitable for remelting. The plastic and cardboard packaging can be recycled.



# Labelling

Product name



Model  
Seat width  
Seat depth  
Max. user weight



Serial number  
CE labelling



Year and month  
manufactured



Specification of  
lifting points



Pitch angle



# Accessories

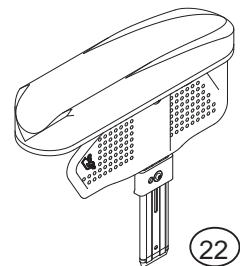
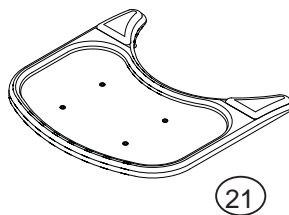
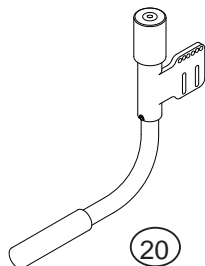
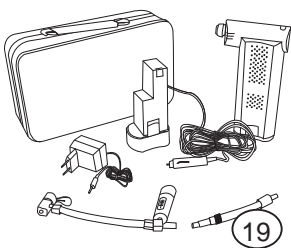
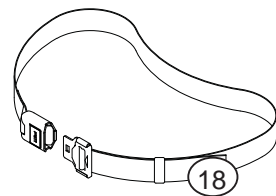
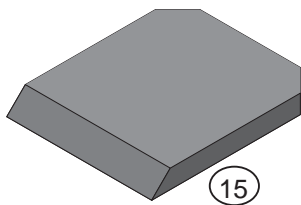
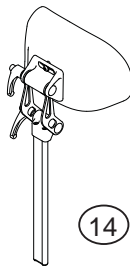
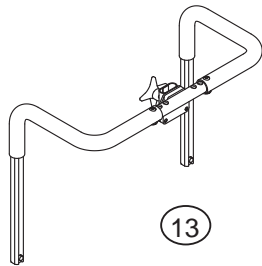
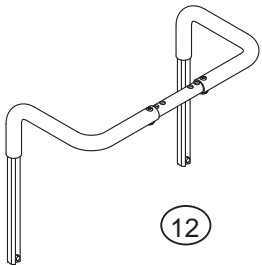
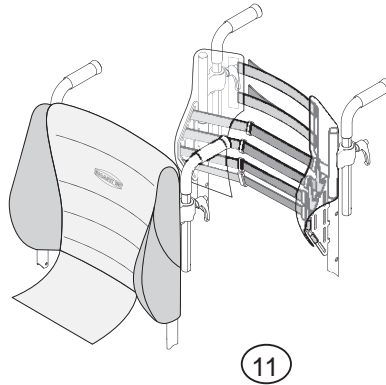
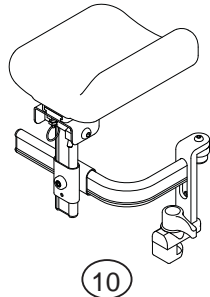
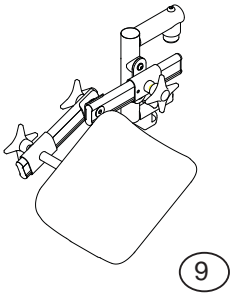
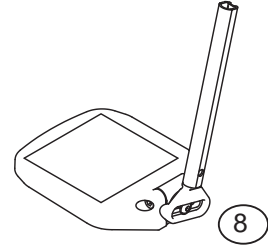
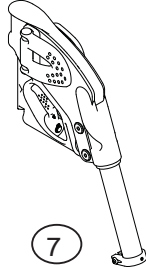
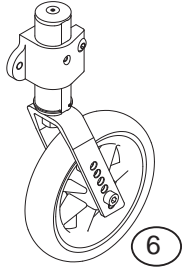
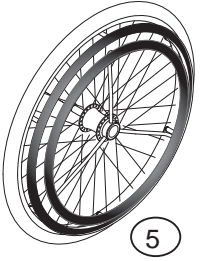
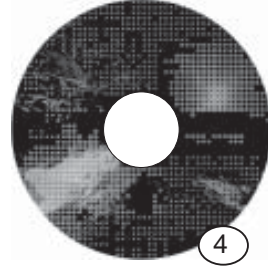
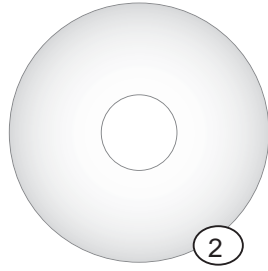
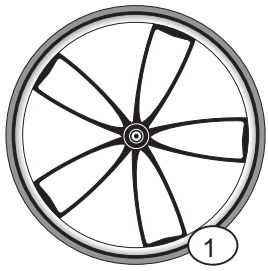

# Accessories

## Driving wheel and driving wheel fastening

- Driving wheel fastening with Impera wheel block (enables the camber angle to be adjusted)
- Amputation block
- Driving wheel with different dimensions and tyres – solid, high pressure and pneumatic
- Spider wheel (1)
- Single hand operated wheel (5)
- Friction hand rim
- Friction cover
- Spoke protectors (2)(3)(4)
- Additional brake for assistant
- Quick-release catch for poor hand function

## Castor wheel and castor wheel fastening

- Castor wheel, with different dimensions and tyres – solid and pneumatic
- Castor wheel forks in different sizes
- Small spirit level for castor angle (6)

## Brakes

- Brake – pull to lock with long lever

## Leg support

- Leg support, angle adjustable (7)
- Footplate, depth adjustable (8)
- Amputation support (9)(10)

## Back

- Smartsit comfort back (11)
- Angled pushing handle
- Pushing handle (12)

- Pushing handle for neck support (13)
- Neck support (14)

## Armrests and clothes protector

- Armrests with short pads, standard height
- Armrests with long pads, high
- Armrests with short pads, high
- Hemiplegia armrest (22)
- Clothes protector

## Miscellaneous accessories

- Pump, electric (19)
- Crutch holder
- Table (21)
- Seat cushion (15)
- Seat cushion Smartsit Basic (16)
- Seat cushion Smartsit Comfort (17)
- Hip belt (18)
- Fitting for hip belt
- Rucksack
- Satchel
- Anti-tip stabiliser, swing forward using leg (20)

Fittings instructions are supplied with the accessories.

Contact your Handicare distributor for accessories and spare parts.

# Guarantee

**Guarantee:** This guarantee applies to all new Handicare manual wheelchairs sold through authorised Handicare AS dealers.

A 2-year guarantee for the product is valid from the date of delivery. Handicare AS guarantees that the product shall not have any defects with regard to material and design, and that it fulfils all the requirements specified in the sales brochure. Handicare AS guarantees free repairs, maintenance and change of any defect parts, provided that the damage was caused during normal use as described in the user manual.

All part exchanges, service and claims made under the following limited guarantee must be presented to Handicare AS in writing within 45 days of the need for this arising in order to be entitled to compensation.

## Exclusions and limitations

- Equipment that is adjusted by someone other than Handicare AS or a representative from the help centre will not be covered by this guarantee.
- Tyres, tubes and upholstery are not covered by this guarantee.
- Any damage to accessories will not be covered by this guarantee.
- Equipment that is not treated with due care or is used in a way that is inconsistent with the guidelines of this user manual will not be covered by the guarantee.

## Making a claim under the guarantee

Equipment that proves not to work satisfactorily must be returned to the authorised Handicare AS dealer from which it was bought. The dealer will undertake the necessary repairs and service. Handicare AS will do its utmost to provide the dealer with the necessary parts in order to complete the repair, but the guarantee covers neither freight of the equipment to or from the dealer nor a replacement for the buyer's wheelchair whilst it is being repaired.

If the buyer is unable to return the equipment to the authorised Handicare AS dealer that sold it, the buyer should contact Handicare AS's head office, tel. +47 69 24 44 00, in Norway in order to obtain the name of an authorised dealer than can undertake the repair under guarantee. The buyer should quote the model number, serial number, purchase date and a description of the equipment's fault in all communication with the dealer.



PO BOX 163  
NO-1501 Moss  
Norway  
[www.Handicare.com](http://www.Handicare.com)

# Notes

# Notes

# Notes

**Warning:** The content of this user manual is only intended as information. This information may be changed without warning and must not therefore be interpreted as an obligation on the part of Handicare Produksjon AS. Handicare Produksjon AS is not responsible, either legally or financially, for any errors or inaccuracies that may appear in this user manual. All products that are mentioned in this user manual are registered trademarks and cannot be used in other contexts without the consent of Handicare Produksjon AS.

Produced by:



Handicare Produksjon AS

[www.Handicare.com](http://www.Handicare.com)